

WEIGHT
158g

CENTER OF GRAVITY with respect to coordinate frame:
X Y Z 1.4277659e-01 -1.9617961e+01 2.5456933e+00 MM

INERTIA at CENTER OF GRAVITY with respect to coordinate frame: (GRAM * MM^2)

INERTIA TENSOR:
Ixx Ixy Ixz 7.8693703e+04 -8.3518130e+02 4.9175097e+02
Iyx Iyy Iyz -8.3518130e+02 4.0971512e+04 -9.1423136e+03
Izx Izy Izz 4.9175097e+02 -9.1423136e+03 6.1356951e+04

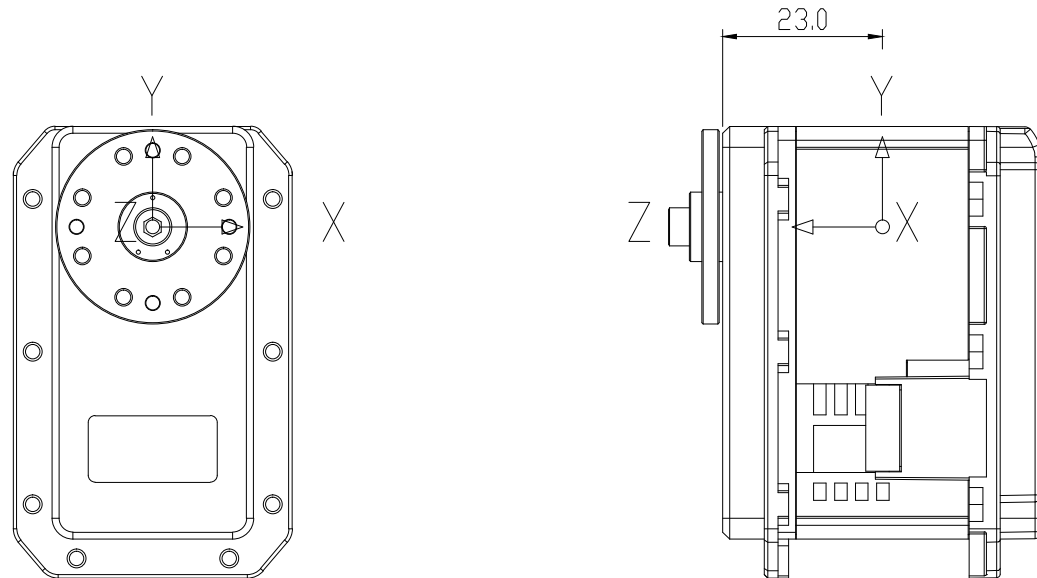

[FOR REFERENCE ONLY]

Title	EX-106/EX-106+	Material	Scale	Unit	Sheet	ROBOTS
			MMSCALE	mm	3 of 3	A4
	DC08_M902	Date				05/15/2009