

4- ϕ 1.6 HOLE DP3.0(Max.)
P.C.D ϕ 12
Using M2 Tapping Screw

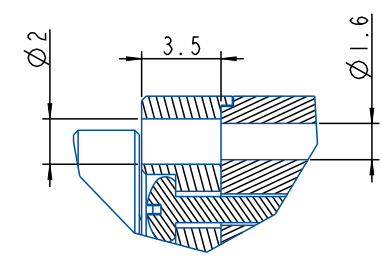

"Detail A"

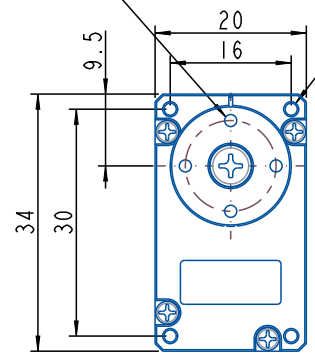
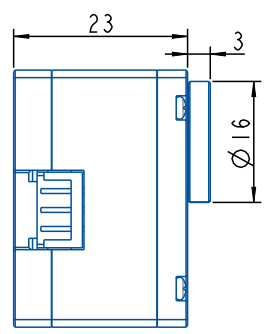
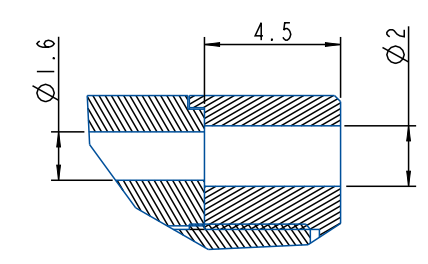

"Detail B"

Using M2 Tapping Screw
View Detail "B"

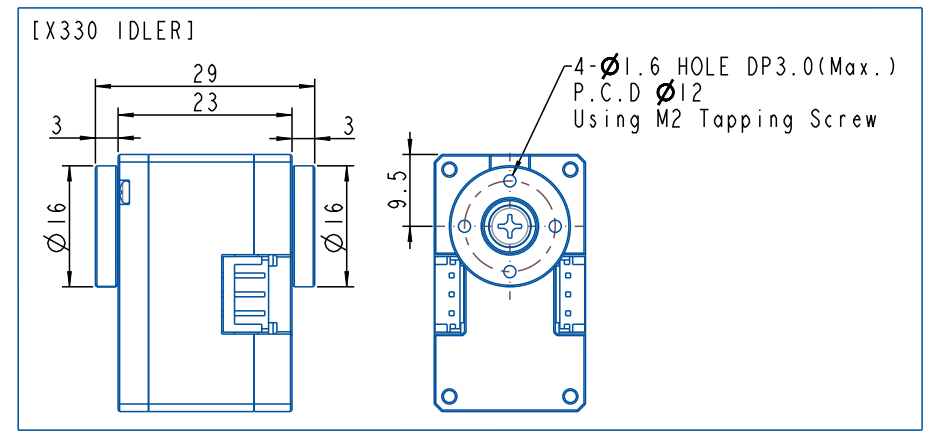
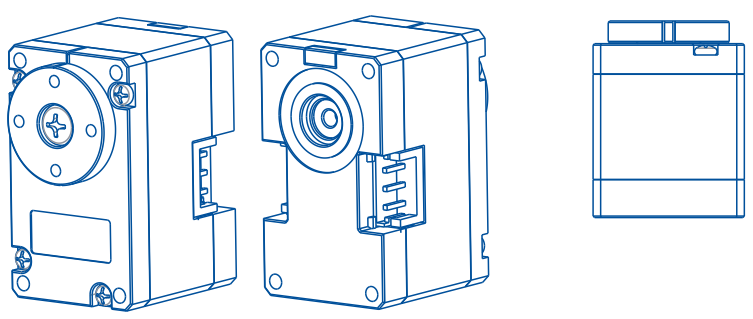
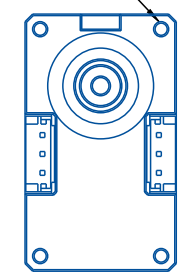
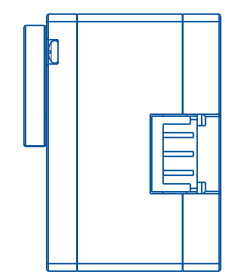

REV.	DESCRIPTION	CHK	DATE

[FOR REFERENCE ONLY]

x330	Material	Scale	Unit	Sheet	ROBOTS
28-May-20		Nonescale	mm	1 of 1	A4